

TGS 4161 - for the detection of Carbon Dioxide

Features:

- * High selectivity to CO₂
- * Compact size
- * Low dependency on humidity
- * Long life and low cost
- * Low power consumption

Applications:

- * Indoor air quality control

TGS4161 is a new solid electrolyte CO₂ sensor which offers miniaturization and low power consumption. A range of 350~5,000ppm of carbon dioxide can be detected by TGS4161, making it ideal for indoor air control applications.

The CO₂ sensitive element consists of a solid electrolyte formed between two electrodes, together with a printed heater (RuO₂) substrate. By monitoring the change in electromotive force (EMF) generated between the two electrodes, it is possible to measure CO₂ gas concentration.

The top of the sensor cap contains adsorbent (zeolite) for the purpose of reducing the influence of interference gases.

TGS4161 exhibits a linear relationship between ΔEMF and CO₂ gas concentration on a logarithmic scale. The sensor displays good long term stability and shows

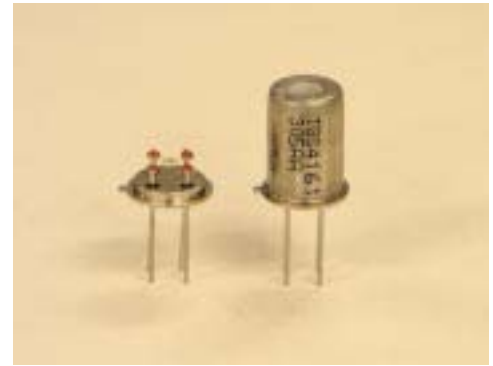

The figure below represents typical sensitivity characteristics of TGS4161. The Y-axis is indicated as ΔEMF which is defined as follows:

$$\Delta EMF = EMF_1 - EMF_2$$

where

EMF₁ = EMF in 350 ppm CO₂

EMF₂ = EMF in listed gas concentration

Sensitivity Characteristics:

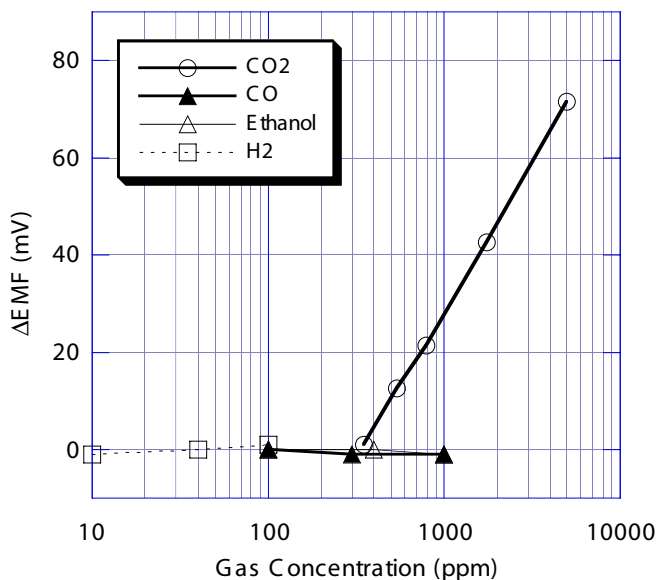

The figure below shows typical humidity dependency of TGS4161. Again, the Y-axis is indicated as ΔEMF which is defined as follows:

$$\Delta EMF = EMF_1 - EMF_2$$

where

EMF₁ = EMF in 350 ppm CO₂

EMF₂ = EMF in 1000ppm CO₂

Humidity Dependency:

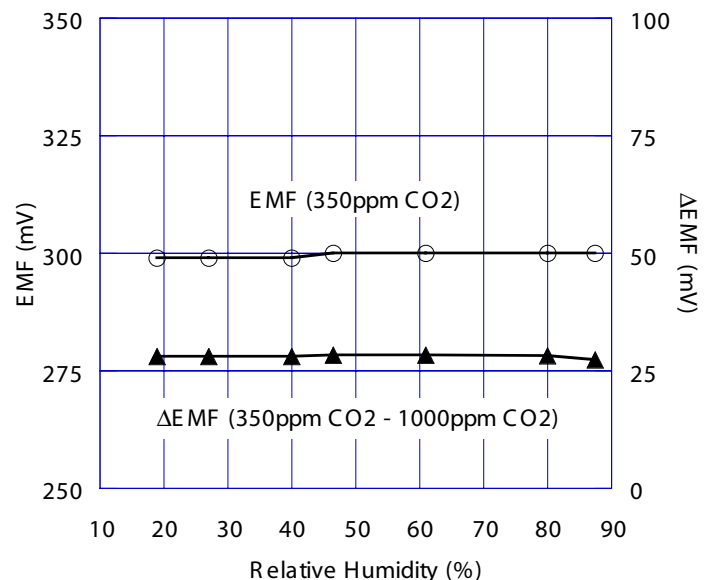

IMPORTANT NOTE: OPERATING CONDITIONS IN WHICH THESE SENSORS ARE USED WILL VARY WITH EACH CUSTOMER'S SPECIFIC APPLICATIONS. WE STRONGLY RECOMMENDS CONSULTING OUR TECHNICAL STAFF BEFORE DEPLOYING THESE SENSORS IN YOUR APPLICATION AND, IN PARTICULAR, WHEN CUSTOMER'S TARGET GASES ARE NOT LISTED HEREIN. WE CANNOT ASSUME ANY RESPONSIBILITY FOR ANY USE OF ITS SENSORS IN A PRODUCT OR APPLICATION FOR WHICH THESE SENSOR HAS NOT BEEN SPECIFICALLY TESTED.

Basic Measuring Circuit:

The TGS4161 sensor requires heater voltage (V_H) input. The heater voltage is applied to the integrated heater in order to maintain the sensing element at a specific temperature which is optimal for sensing. Electromotive force (EMF) of the sensor should be measured using a high impedance ($>100\text{ G}\Omega$) operational amplifier with bias current $< 1\text{ pA}$ (e.g. Texas Instruments' model #TLC271). Since the solid electrolyte type sensor

functions as a kind of battery, the EMF value itself would drift using this basic measuring circuit. However, the change of EMF value (ΔEMF) shows a stable relationship with the change of CO_2 concentration. Therefore, in order to obtain an accurate measurement of CO_2 , a special microprocessor or signal processing should be used with TGS4161. Figaro can provide a special evaluation sensor module (AM-4-4161) for TGS4161.

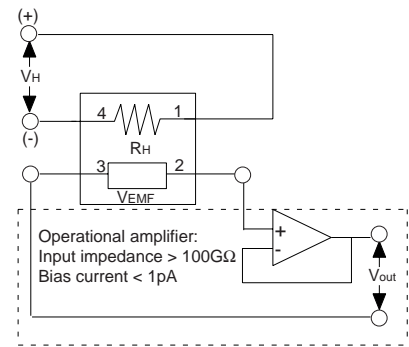

Specifications:

| | | | | | |
|----------------------------|---------------------------------|---|--------------------------------------|---|--|
| Model number | | 1 | TGS 416 | | |
| Sensing element type | | e | Solid electrolyt | | |
| Target gases | | e | Carbon dioxid | | |
| Typical detection range | | m | 350 ~ 5000 pp | | |
| Electrical characteristics | Heater resistance | R_H | $70 \pm 7\Omega$ at room temp. | | |
| | Heater current | I_H | approx. 50mA | | |
| | Heater power consumption | P_H | approx. 250mW | | |
| | Electromotive force | EMF | 220~490mV @ 350ppm CO_2 | | |
| | Sensitivity | ΔEMF | 44~72mV | EMF (350ppm CO_2) - EMF (350ppm CO_2) | |
| | Heater voltage | V_H | $5.0 \pm 0.2\text{V (DC)}$ | | |
| Sensor characteristics | Response time | approx. 1.5 min. (to 90% of final ΔEMF value) | | | |
| | Measurement accuracy | approx. $\pm 20\%$ at 1,000ppm CO_2 | | | |
| Operating conditions | | H | $-10 \sim 50^\circ\text{C}$, 5~95%R | | |
| Storage conditions | | $-20 \sim 60^\circ\text{C}$, 5~90%RH (store in moisture proof bag with silica gel) | | | |
| Standard test conditions | Test gas condition | CO_2 in air at $20 \pm 2^\circ\text{C}$, 65 \pm 5%RH | | | |
| | Circuit condition | V | $H = 5.0 \pm 0.05\text{V DC}$ | | |
| | Conditioning period before test | 12 hours or longer | | | |

Structure and Dimensions:

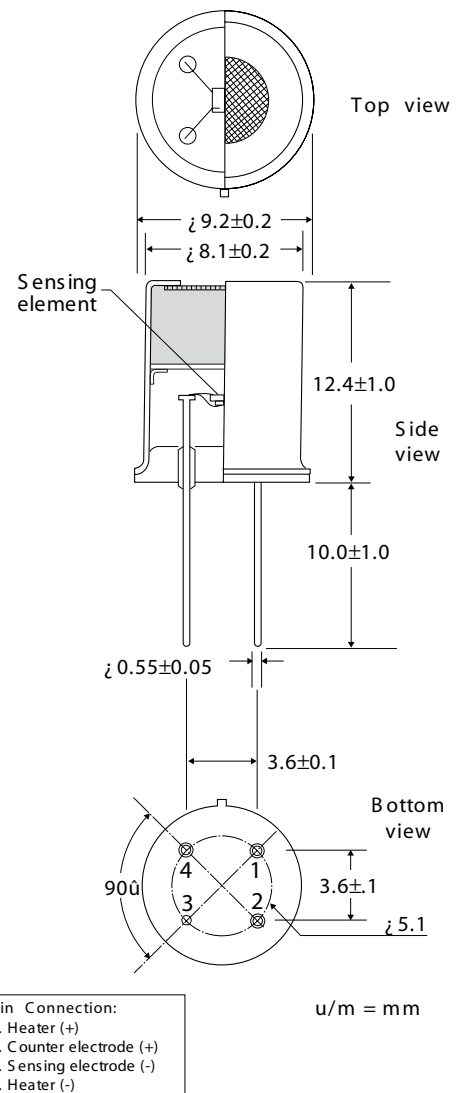

Sensing Element Structure:

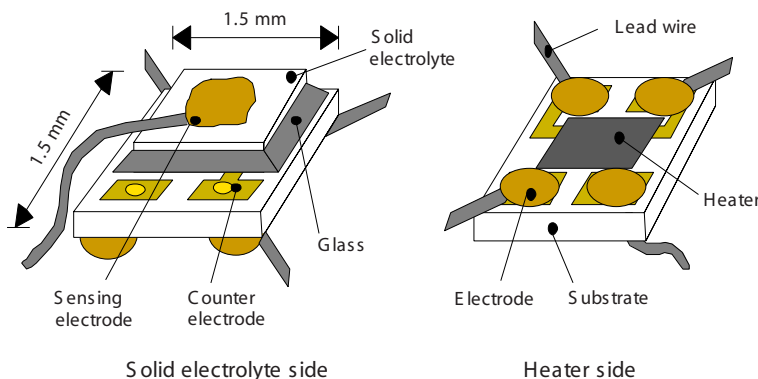

Due to continuous product improvement, the design and technical specifications are to subject change without prior notice

TBS LTD.,

29-M-1003, Shin-Ashiya-Kami, Suita-shi, Osaka 565-0804, Japan

Tel: +81-6-6876-9035 Fax: +81-6-6876-9135

e-mail: tashika@gol.com

URL: <http://www.tashika.co.jp>