

# TGS 6810-D00 - for the detection of Methane and LP Gas

### Features:

- \* Linear output
- \* Long life
- \* Small sensitivity to alcohol
- \* Sensitive to both methane and LP gas

### Applications:

- \* Residential LNG and LPG alarms
- \* Detectors for LNG and LPG

The **TGS6810-D00** catalytic type gas sensor, which can detect both methane and LP gas, has been developed for residential gas detection. Combining Figaro's extensive experience in catalyst materials technology with its advanced micro fabrication technology, Figaro can produce the most advanced compact catalytic sensors whose durability, stability, quick response, and linear output make them ideal for detecting many combustible gases.

As the sensor possesses an adsorbent inside its sensor cap, its cross sensitivity to alcohol is small. In addition, TGS6810-D00 is durable against silicone compounds. Expected sensor life is 10 years in a normal indoor environment (based on actual long term stability data of more than 8 years).



The figure below represents typical sensitivity characteristics, all data having been gathered at standard test conditions (see reverse side of this sheet). The Y-axis is indicated as sensor output sensitivity-- $\Delta V_{out}$  (mV):

$$\Delta V_{out} = V_{out} \text{ in gas} - V_{out} \text{ in air}$$

The figure below represents typical temperature dependency characteristics at 65%RH. Again, the Y-axis is indicated as sensor output sensitivity-- $\Delta V_{out}$  (mV):

$$\Delta V_{out} = V_{out} \text{ in gas} - V_{out} \text{ in air at } 20^{\circ}\text{C}$$

**Sensitivity Characteristics:**

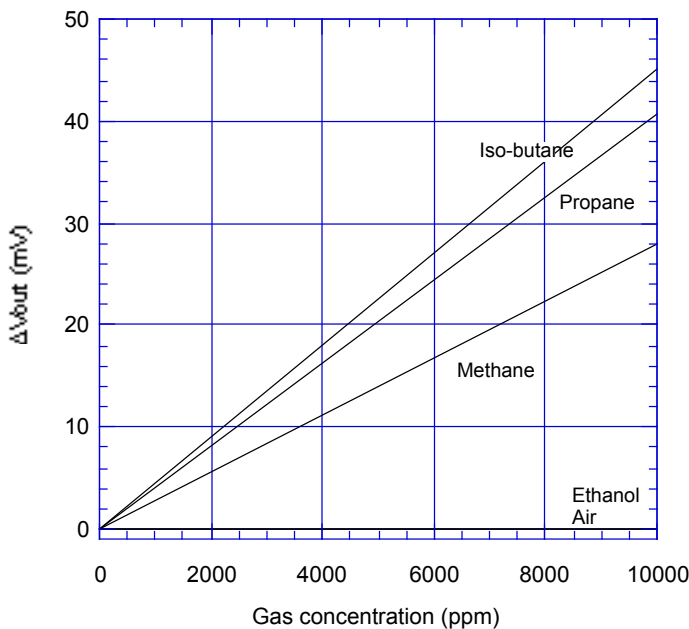

**Temperature Dependency:**

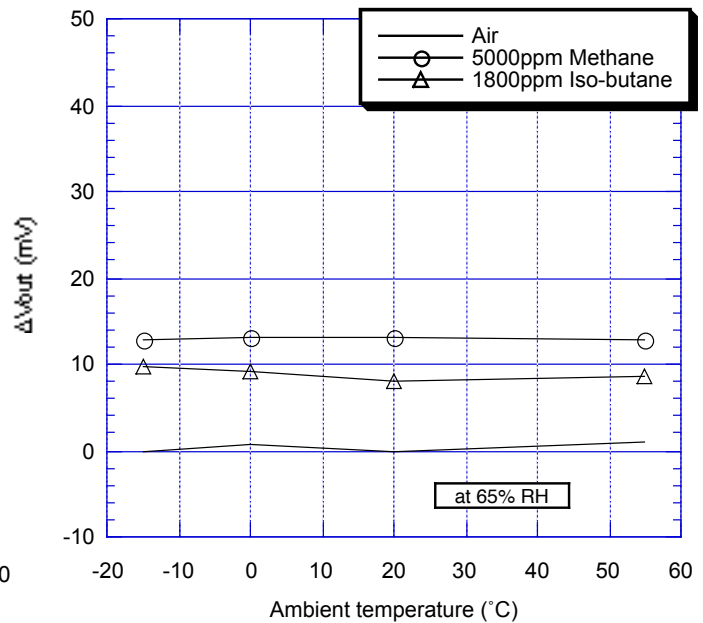

**IMPORTANT NOTE:** OPERATING CONDITIONS IN WHICH FIGARO SENSORS ARE USED WILL VARY WITH EACH CUSTOMER'S SPECIFIC APPLICATIONS. FIGARO STRONGLY RECOMMENDS CONSULTING OUR TECHNICAL STAFF BEFORE DEPLOYING FIGARO SENSORS IN YOUR APPLICATION AND, IN PARTICULAR, WHEN CUSTOMER'S TARGET GASES ARE NOT LISTED HEREIN. FIGARO CANNOT ASSUME ANY RESPONSIBILITY FOR ANY USE OF ITS SENSORS IN A PRODUCT OR APPLICATION FOR WHICH SENSOR HAS NOT BEEN SPECIFICALLY TESTED BY FIGARO.

### Basic Measuring Circuit:

The TGS6810 is comprised of two elements: 1) element (D) which is sensitive to combustible gases and 2) a reference element (C) which is not sensitive to combustible gases. These elements are installed into a "Wheatstone Bridge". A variable resistor should be adjusted so that the bridge will produce a stable baseline signal when in an environment free of combustible

gases. When combustible gases are present, they will be combusted on the detecting element, causing its temperature to rise. Accordingly the resistance of this element will increase. This results in an "out-of-balance" signal across the bridge and a corresponding change in output voltage which can be measured.

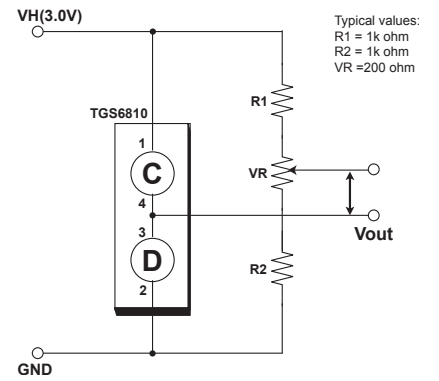

### Specifications (tentative)

Model number		TGS 6810-D00	
Sensing element type		Catalytic	
Target gases		Methane, propane, iso-butane	
Typical detection range		0~100%LEL of each gas	
Standard circuit conditions	Operating voltage	3.0±0.1V AC/DC	
Electrical characteristics under standard test conditions	Heater current	175mA (typical)	
	Heater power consumption	525mW (typical)	
	Zero offset	-15 ~ +55mV	
	Output sensitivity (ΔVout)	methane	10~18mV in 5000ppm
iso-butane		6~12mV in 1800ppm	
Standard test conditions	Test gas conditions	Methane/iso-butane in air at 20±2°C, 65±5%RH	
	Circuit conditions	3.0±0.05V AC/DC	
	Conditioning period before test	≤30 sec.	
Operating conditions		-10°C~+50°C, ≤95%RH (w/o dew condensation)	
Storage conditions		-10°C~+60°C, ≤95%RH (w/o dew condensation)	

### Structure and Dimensions:

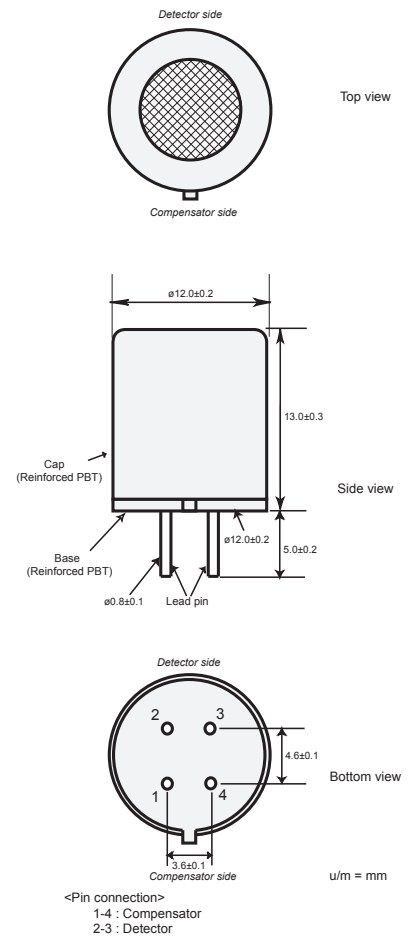

All sensor characteristics shown in this brochure represent typical characteristics. Actual characteristics vary from sensor to sensor. The only characteristics warranted are those in the Specification table above.

**Tsdpl**  
**TOSHIWAL SENSING DEVICES PVT. LTD.**  
 E-19/20, INDUSTRIAL ESTATE MAKHUPURA, AJMER-305002, INDIA  
 TEL: +91-145-2695482, FAX: +91-145-2695006  
 CUSTOMER CARE: +91-9571897879  
 E-MAIL: soles@tsdpl.com, WEBSITE: www.tsdpl.com